

IEP-D

2+2+2 movement
MODULE 2 serrations

High precision 6 jaw chucks 2+2+2 equalising Ø 1000 - 1600 mm

- closed center
- Equalising mechanism lockable



Application/customer benefits

- Clamping of thin walled work pieces
- Low radial deformation with 2+2+2 clamping
- Suitable for horizontal and vertical machines

Technical features

- Adjustable to 6 jaw 2+2+2 or true 6 jaw clamping
- Constant gripping force with permanent lubrication
- Centrifugal compensation for high spindle speed
- **proofline® chucks** = fully sealed – low maintenance

Standard equipment

chuck with mounting bolts
1 set of soft top jaws
grease gun

Ordering example

IEP-D 1250/Z520

Actual gripping force diagram

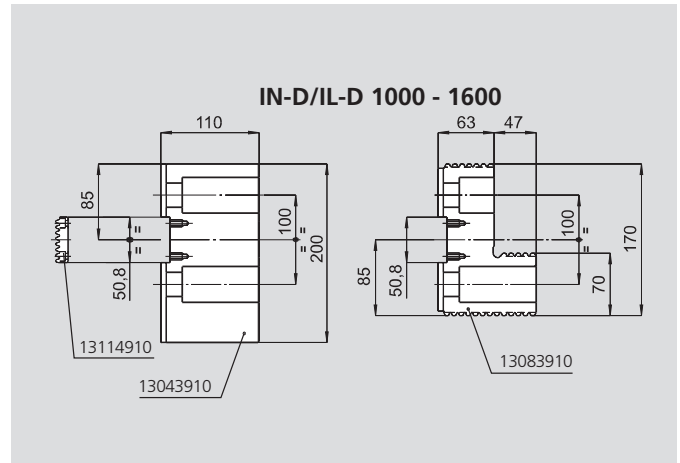
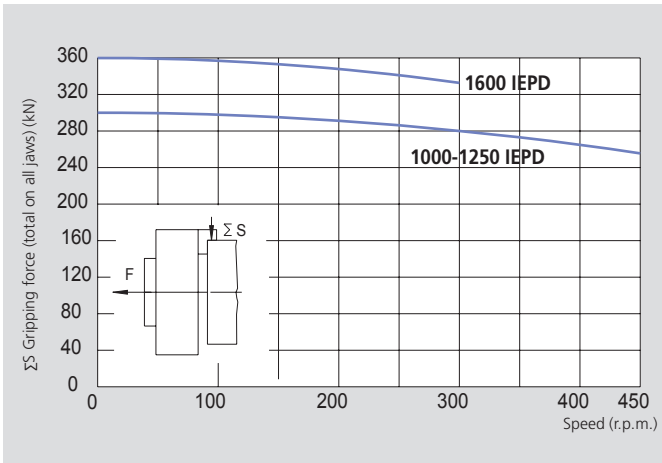

The data in the diagram refer to 6-jaw-chucks, newly maintained according to their service manuals using SMW-AUTOBLOK K67 grease. The static and dynamic gripping forces have been measured using standard soft top jaws, placed in a position not exceeding the outer diameter of the chuck.

⚠ Safety advice/danger of damage:

When using taller/heavier jaws and/or clamping on a bigger diameter reduce draw pull/rotating speed accordingly.

Technical data

SMW-AUTOBLOK Type		IEP-D 1000 2+2+2	IEP-D 1250 2+2+2	IEP-D 1600 2+2+2
Number of jaws				
Radial jaw stroke	mm	20	20	25
Jaw compensation	mm	±5	±5	±5
Axial piston stroke	mm	40	40	50
Max. draw pull	kN	200	200	240
Max. gripping force	kN	300	300	360
Max. speed	r.p.m.	450	400	280
Weight (without top jaws)	kg	1080	1500	2370
Moment of inertia	kg·m ²	127	273	640
Hard top jaw (piece)	Id. No.	13083910	13083910	13083910
Soft top jaw (piece)	Id. No.	13043910	13043910	13043910
Recommended actuating cylinders		SIN-S 200-250	SIN-S 200-250	SIN-S 200-250

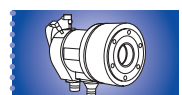

High precision 6 jaw chucks 2+2+2 equalising Ø 1000 - 1600 mm

- closed center
- Equalising mechanism lockable

IEP-D

2+2+2 movement
MODULE 2 serrations

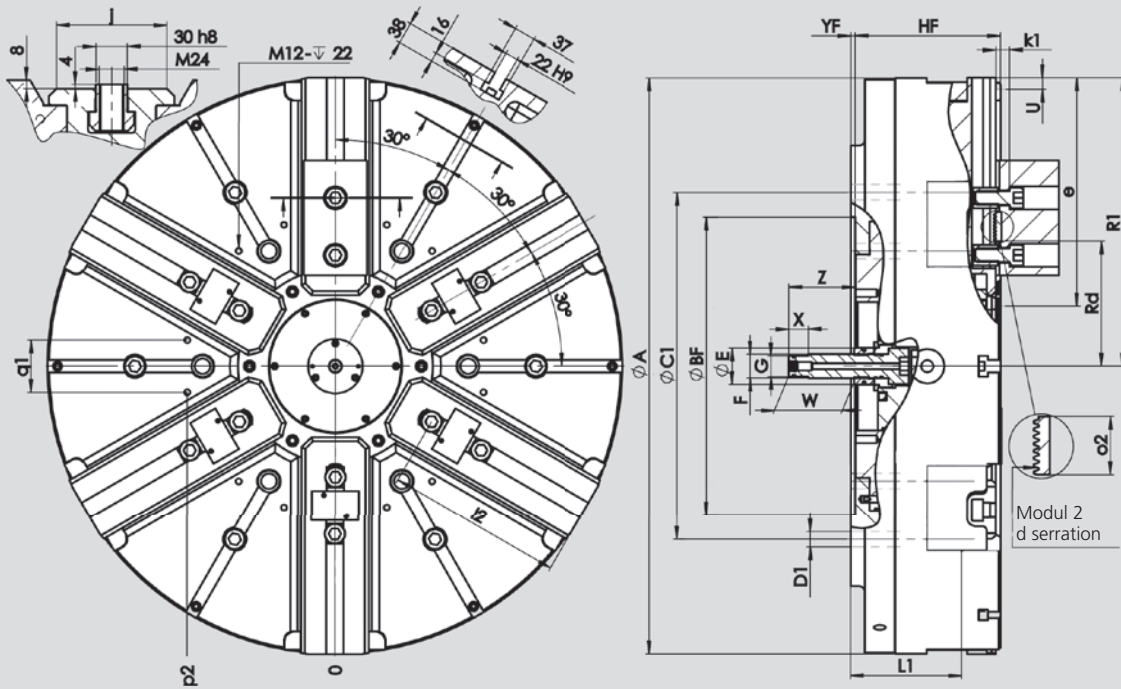

Subject to technical changes
For more detailed information please ask for customer drawing

SMW-AUTOBLOK Type			IEP-D 1000		IEP-D 1250		IEP-D 1600	
	A	mm	1005		1250		1600	
	BF	H6 mm	520		520		720	
	C	mm	463.6		463.6		647.6	
	C1	mm	700		700		1110	
	D	mm	27		27		33	
	D1	mm	27		27		27	
	E	mm	64		64		64	
	F	mm	M42 x 3		M42 x 3		M42 x 3	
	G	H8 mm	36		36		36	
	HF	mm	254		254		272	
	L	mm	186		186		225	
	L1	mm	194		194		233	
Chuck open	R1	mm	498		620.5		798.5	
Chuck open	Rd	mm	228		228		288.5	
Jaw stroke	U	mm	20		20		25	
	W	mm	114		114		114	
	X	mm	34		34		34	
	YF	mm	8		8		8	
max./min.	Z	mm	156	116	156	116	156	106
	d	M	Module 2		Module 2		Module 2	
	e	mm	345		465		595	
	j	mm	105		105		131	
	k1	mm	24		24		24	
max./min.	l2	mm	295	118	417	118	531	118
	o2	mm	50.8		50.8		50.8	
	p2	mm	258.5		258.5		*	
	q1	mm	91		91		*	

* please ask for a chuck drawing